

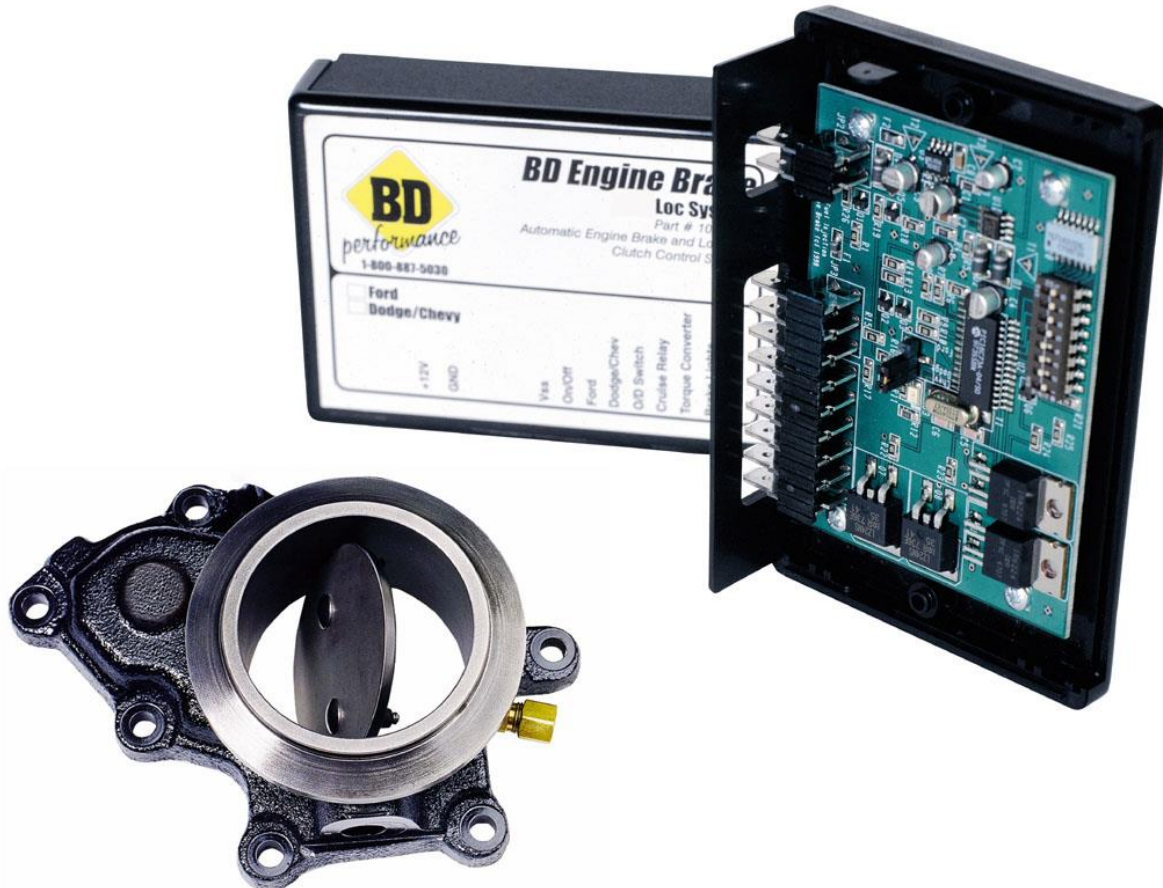

**DOWNLOAD COLOR
INSTALL MANUALS AT
www.bddiesel.com**



BD BrakeLoc EBP Valve Control Ford Powerstroke (Automatic Transmissions)

Part# 1030750

Please read this instruction manual before starting installation

TABLE OF CONTENTS

Welcome.....3

The BD BrakeLoc Advantage.....3

Notes on Connectors3

Operating The BD BrakeLoc.....4

Adjusting For Application4

DFIV Module Installation.....5

Cruise Control Disconnect Wiring6

BrakeLoc Module Wiring.....6

 BrakeLoc power lead (Red wire).....6

 BrakeLoc ground (Black wire).....6

 Vehicle Speed Sensor (Green wire).....7

 Brake Power Signal (Brown Wire).....7

 Overdrive Switch (White wire).....7

 Converter Control (Yellow #6 and Blue #7 wire))7

 Not applicable to this kit.....7

 BD Powerstroke Brake (Gray Wire)7

EBP Valve Wiring.....7

Wiring Diagram10

DFIV Adjustment & Testing.....11

Testing.....12

Ford Exhaust Brake RetroFit Kit (California Trucks).....12

Welcome

Thank you for purchasing the BD **BrakeLoc** Kit. This manual is to aid you with your installation and operation of the unit. We strongly suggest that you retain this manual for any future reference.

The BD BrakeLoc Advantage

Though not as efficient as a **BD Exhaust Brake**, the **BD BrakeLoc** offers a cost effective solution of engine retarding for towing with the automatic transmission on the Ford PowerStrokes.

The **BrakeLoc** commands the **Exhaust Back Pressure (EBP)** valve to activate as well as keeping the lock-up clutch of the torque converter to stay engaged to allow up to 100% of the retarding force to be transferred while in 3rd and 4th gear. Also, transmission oil temperatures will remain low because of little or no slippage occurring in the converter in these gears.

Notes on Connectors

The kit includes a number of Posi-Tap™ connectors (Gray/Black/Green) to tap onto OEM wiring. It is important to select the correct color of connector so that it matches the gauge of the OEM wire that it is being installed on. Using the incorrect connector could cause an inadequate connection and/or the OEM wire could be severed.

OEM Wire	Posi-Tap™ Color
18-22ga	Gray
12-18ga	Black
10-12ga	Green

Though these connectors offer a quicker installation, the best option would be to solder the wires and isolate the joints with heat shrink or liquid electrical tape. Proper soldering techniques should be used to ensure adequate connections.

Posi-Tap™ Connector Usage Diagram

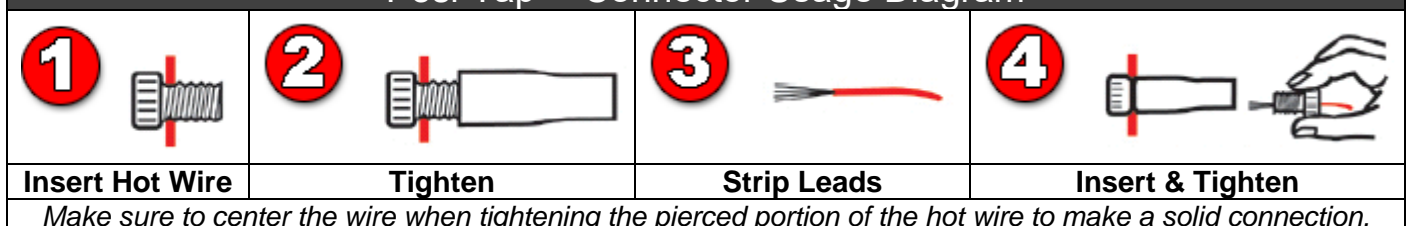

Operating The BD BrakeLoc

Once the toggle switch for the **BD BrakeLoc** is turned on, the module monitors two signals - **vehicle speed** and **accelerator pedal position**. When the vehicle speed has surpassed the set speed (approximately 25 to 30 mph) and the accelerator pedal is at the "idle" position, the module will begin to activate the **EBP** valve, and keep the lock-up clutch in the torque converter engaged. Once the module has activated the **EBP** valve, there will be about a 3 second delay before you will feel and hear the **EBP Valve** apply.

When the vehicle speed drops below the set speed, the accelerator pedal is applied, or, the toggle switch is turned off, the module will disengage the **EPB** valve and release its hold on the lock-up clutch.

For the **BrakeLoc** to keep the lock-up clutch engaged, the clutch must already be activated. The lock-up clutch usually engages when the vehicle is cruising with little throttle action. On most vehicles, the lock-up clutch will be engaged by applying pressure to the accelerator pedal until lock-up engages, then lift foot off of the accelerator.

If vehicle speed drops below 40mph, the transmission should be shifted out of overdrive otherwise lock-up will be lost. When this occurs, manually deactivate the overdrive and the lock-up clutch will reengage.

Other installed aftermarket or performance products may affect the operation of the transmission and may have an effect on the operation of the **BD BrakeLoc**. Please make this known when contacting the BD Technical Service Department.

Adjusting For Application

Before starting the installation, open the control box up by removing the two Phillips screws on the bottom of the module. On the opposite end of the circuit board from the terminals, there is selection of 8 "dip" switches. The dip-switches control the speed that the **BrakeLoc** module will disconnect the lock-up clutch. We have provided settings for the module to disconnect the lock-up at approximately 25mph to 30mph. If you find the set speed too high or too low for the vehicle, phone our technical service department for alternative settings.

NOTE: To insure proper function of the dip-switches, flip each dip-switch back and forth once before setting them, even if the dip-switches are already set for the application being installed on.

The “LED” (Light Emitting Diode) on the circuit board will show a Red light when the **BrakeLoc** is functioning.

Once the unit is installed, test drive the vehicle to make sure the light does come on and then turns off at the set speed.

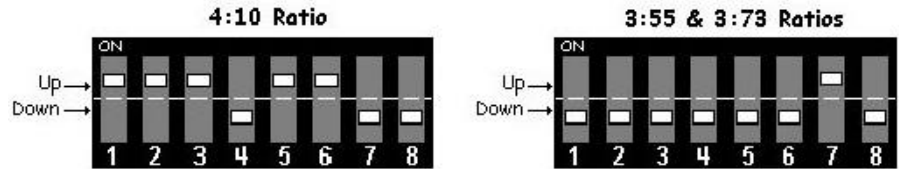
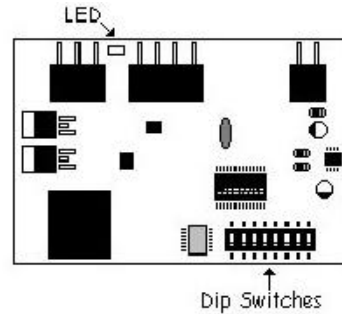

DFIV Module Installation

CAUTION: Before installing any wiring modifications or equipment ensure to disconnect the battery Ground (Negative) terminals on all vehicle batteries as damage to the vehicle’s ECU and/or installed component may result.

When possible, check for continuity through all Posi-Tap connectors after you have installed them. We suggest soldering and shrink tubing all connections but provide Posi-Taps for your convenience.

Remove knee bolster, under the steering column, and mount the DFIV module to the cross member under the steering column.

GROUND Locate the supplied **black** wire with ring terminal. Install the ring terminal under a clean bolt under the dash that has a good ground connection. Trim this wire to length and strip the end, install in the DFIV module “Ground” terminal.

TOGGLE SWITCH Locate the supplied toggle switch wire assembly. The **red** wire with fuse holder will be connected to switched 12v from the truck. Using a Posi-Tap™ connector, attach the fused wire from the toggle switch to either one of the two Red w/Black tracer wires (ignition switched power) under the steering column. Mount Toggle Switch in a convenient spot on the dash. The remaining **red** wire from the toggle switch will connect to the DFIV “SWITCH” terminal. The **black** wire from the toggle switch will connect to the DFIV “GROUND” terminal along with the other wire already installed.

TPS/APPS Locate the Throttle Position Sensor (TPS) at the throttle pedal and, using a Posi-Tap connector, attach the **yellow** wire attached to the “TPS/APPS” terminal on the DFIV module to the **grey w/white** tracer wire on the trucks TPS.

FORD Connect the **violet** wire to the “Ford” terminal of the DFIV module. Leave the other end of the wire for now.

COM Connect the **pink** wire to the “Com” terminal of the DFIV module. Leave the other end of the wire for now.

BRAKE Connect the **brown** wire from the “Brake” terminal of the DFIV module. Leave the other end of the wire for now. This will connect to the Autoloc module.

Run the other end of the pink and violet wires through a grommet on the firewall making sure all wires are secure and away from moving objects and heat sources. Reinstall the lower dash cover.

Cruise Control Disconnect Wiring

Consult the wiring diagram on page 10 for proper connections.

Locate the Brake Applied Switch on the master cylinder.

Expose the wiring approximately 3 - 6 inches from the switch, cut the Black wire w/Yellow tracer (BK/Y), then strip both ends and attach a blue Posi-Lock to each side.

Run the **Pink** and **Violet** wires that were brought through the firewall and connect them to the connectors just attached to the Black wire w/Yellow tracer. The order is not important.

BrakeLoc Module Wiring

The following instructions will be divided up to each individual terminal labeled on the **BrakeLoc** module, and the terminals in these instructions will be numbered starting from #1 at the +12V terminal. Refer to the diagram presented after the written instructions for ease of installation.

You may want to remove the driver side front fender well for access to the computer harness. When possible, check for continuity through all Posi-Tap™ connectors after you have installed them. We suggest soldering and shrink tubing all connections, but provide Posi-Taps for your convenience.

+12V	#1	BrakeLoc power lead (Red wire)
Using a test light or multi-meter, find a key switched +12 Volt power source in the wiring harness under the dash. Connect the Red wire to it using a black Posi-Tap™ and connect the other end of the Red wire to the +12v terminal on the module.		

GND	#2	BrakeLoc ground (Black wire)
------------	-----------	-------------------------------------

Connect to any bolt/screw under the dash that is a good ground.

VSS	#3	Vehicle Speed Sensor (Green wire)
------------	-----------	--

Locate the **VSS** (Vehicle Speed Sensor) wire in the vehicles computer wiring harness (see chart). Run the **BrakeLoc Green** wire to the **VSS** wire and cut off any excess, leaving some slack. Connect to the **VSS** wire using a gray Posi-Tap™, or, solder the **Green** wire to the **VSS** wire and protect it from the elements (i.e. liquid electrical tape).

FORD (7.3L)	1995-2003	Pin 58 at ECM (Gray w/Black Tracer)
--------------------	------------------	---

BPS	#4	Brake Power Signal (Brown Wire)
------------	-----------	--

Install the brown wire from the 'BRAKE' terminal of the DFIV module to this terminal on the control box.

O/D SW	#5	Overdrive Switch (White wire)
---------------	-----------	--------------------------------------

Not applicable to this kit.

PCM & TCC	#6-7	Converter Control (Yellow #6 and Blue #7 wire))
----------------------	-------------	--

Locate the vehicles **Torque Converter Control** (TCC) as described in the following chart. Cut the applicable wire and attach a blue Posi-Lock™ to the wire leading back to the transmission and attach the other side to the wire heading to the vehicles computer (ECM or PCM).

Connect the **BrakeLoc Yellow** wire to the PCM (#6) terminal on the module, and, connect the **Blue** wire to the TCC (#7) terminal. Run the **Yellow** and **Blue** wire to the cut Converter Control wire and cut off leaving some slack. Attach a blue Posi-Lock™ connector to the **Yellow** wire and connect to wire heading to vehicle's computer. Attach the other end to the **Blue** wire and connect to wire heading back to transmission. Instead of connectors, you could also solder the wires.

NOTE: Some vehicles have more than one wiring harness on transmission.

Make/Model	Year	Wire Color	Pin #	Location
FORD (7.3L)	1999-2003	VT/Y	54	PCM
	1995-1997	VT/Y	28	PCM

INVERTER	#8	Not applicable to this kit.
-----------------	-----------	------------------------------------

BRAKE	#9	BD Powerstroke Brake (Gray Wire)
--------------	-----------	---

This wire runs to the EBP valve under the hood.

EBP Valve Wiring

For 1994-1997 Powerstrokes, a direct plug in wiring harness is supplied to connect to the EBP valve. Disconnect the EBP valve wiring harness connection (see page 8) and plug in the small harness supplied with this kit (1300742).

The **red** wire from the supplied EBP valve harness will be connected to the **gray** wire run from the Autoloc **BRAKE** terminal.

Use a blue Posi-Lock connector supplied the end of the pink wire to the red wire.

For 1999-2003 Powerstrokes (and any retrofitted early models), we do not supply a plug in harness. Instead, run the **gray** wire that was brought through the firewall and tap it into the EBP valve wiring harness using a black (14-18ga) or grey (18-22ga) Posi-Tap. The wire to tap into is the **GRAY/RED**, not the BLACK ground wire.

Early (left) vs late (right) EBP solenoids for reference.



To gain access to the EBP Valve and wiring, remove the top intercooler hose and then remove the sensor hose and wire connector from the MAP sensor.

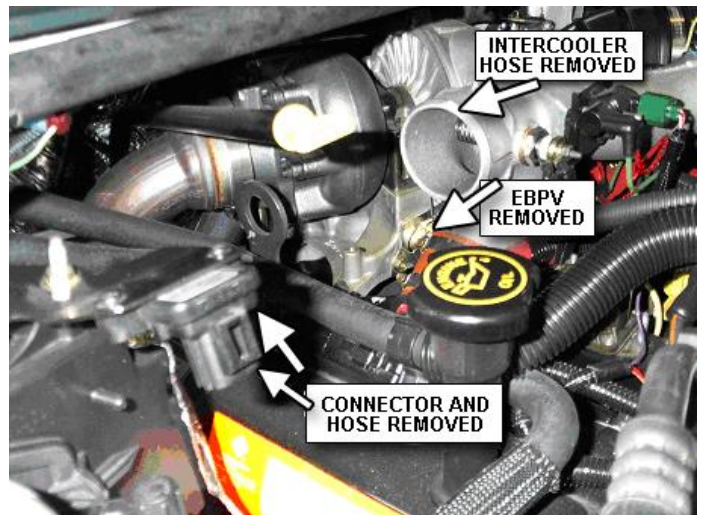
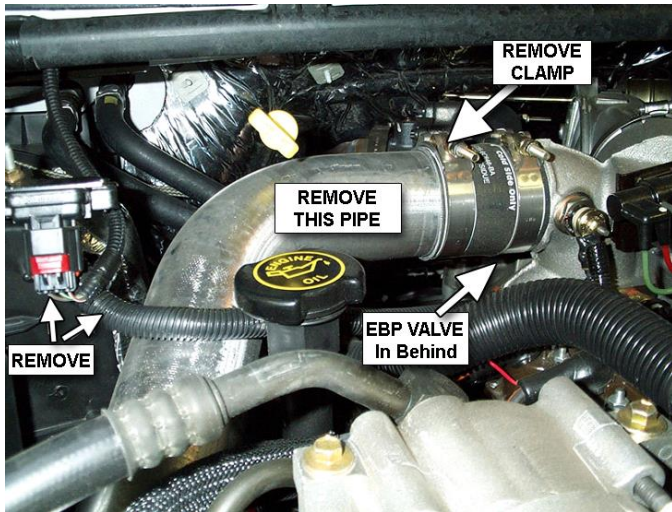

For ease of access and hook up, remove the connector from the EBP Valve and pull the wiring through and underneath to the front of the intake Y-plenum. This will allow access to install a Posi-Tap™ or Connector harness.

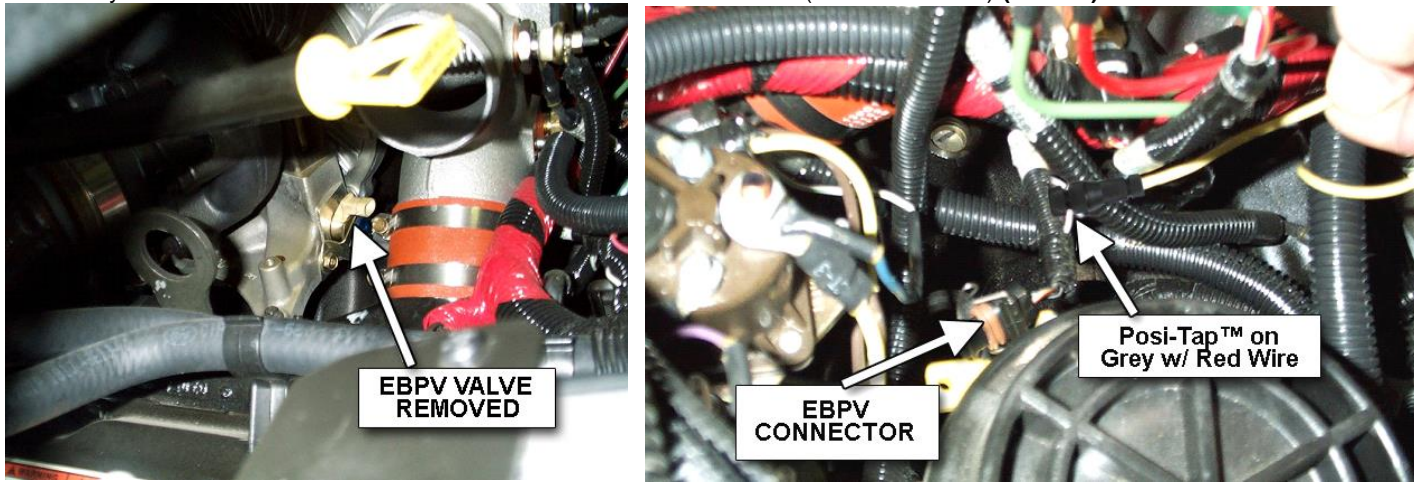

NOTE: After installation, ensure to replace the intercooler hose and clamps. Reattach the MAP sensor hose and wiring connector. Check all connections for security and tightness and secure all wiring to ensure they are out of the way of moving and heated items.

Reconnect and secure all battery connections removed at the beginning of this installation.

Wiring Diagram

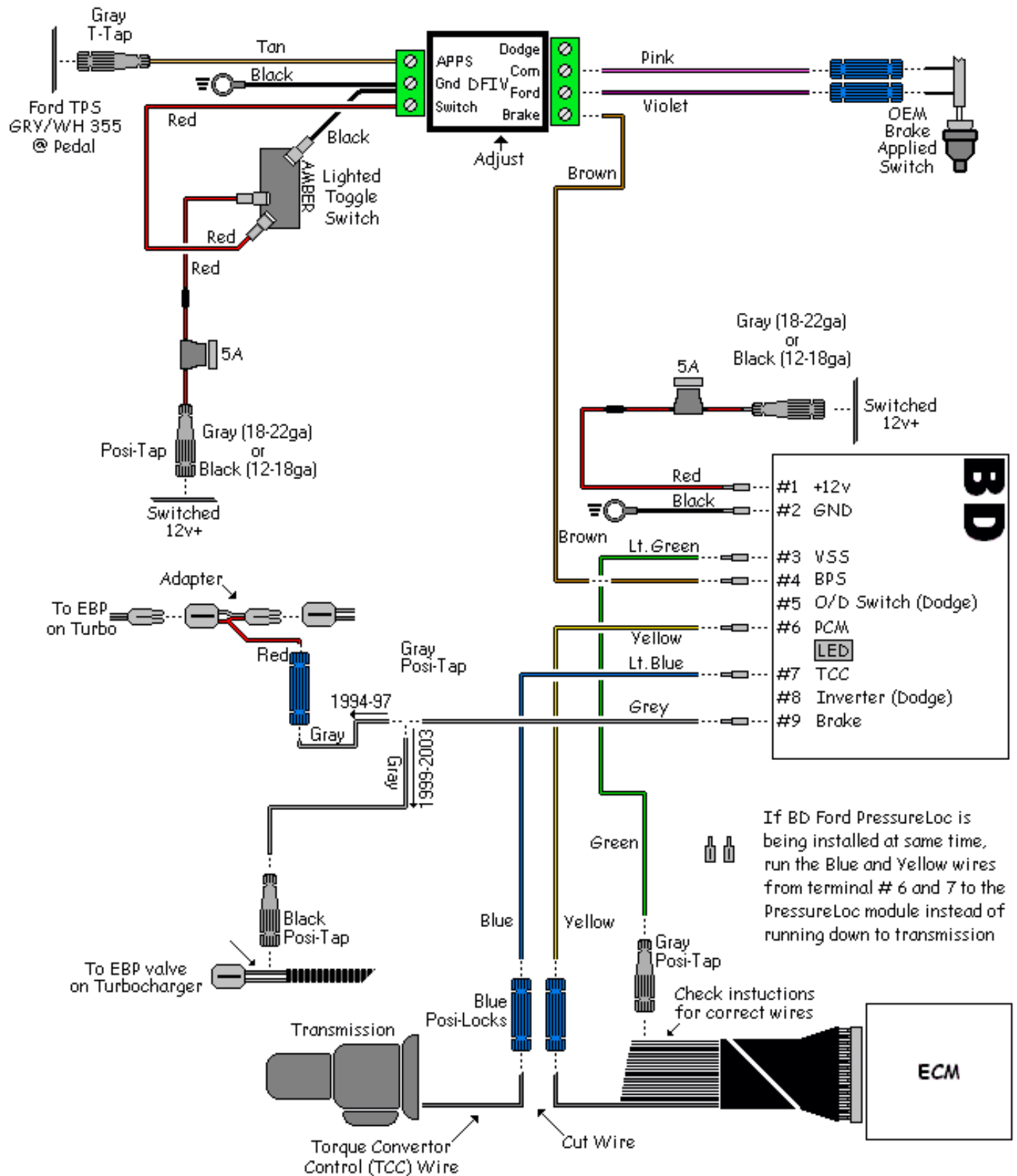

DFIV Adjustment & Testing

Ensure the connections of the corresponding wires to the DFIV Control Module are correct as shown in the wiring diagram.

To achieve the correct setting for the activation of the exhaust brake in relation to the throttle pedal the DFIV Module must be calibrated for your vehicle.

Connect a test light to the 'BRAKE' terminal of the DFIV module.

With the throttle at idle, start the engine and turn on brake switch. Then, using a small flat bladed screwdriver, turn the small adjusting screw in the DFIV Module counterclockwise or clockwise until the test light JUST turns on.



CAUTION: THE ADJUSTING SCREW IS A MICRO-SWITCH WHICH IS VERY DELICATE, SO TURN USING SMALL ADJUSTMENTS.

Test by revving up the engine to approximately 1200 RPM and releasing the throttle. As the accelerator pedal is applied the test light should turn off just before the engine starts to rev, indicating proper calibration of the DFIV Module with the APPS.

Then the test light should activate again when the throttle pedal returned to idle. If not, readjust the DFIV Module so that it does.

Check for any exhaust leaks and recheck all connections and hoses for security and interference from moving or heated items. After about 100 miles (160 km), re-torque the flange bolts.

Testing

NOTE: When wiring the **BrakeLoc** module, leave enough slack on the wires so that the module can be pulled out enough to be easily visible during road testing, before finally securing unit under dash. Reconnect Ground terminals on batteries after installation and take the vehicle for a drive.

With no traffic around, cruise at a constant speed, above the set speed on the module, with the transmission “locked up”, then let off the throttle.

The **EBPV control** should activate and after about a 3 second delay, you should feel and hear the **EBP Valve** apply. Again, with the lock-up clutch engaged and while cruising, release the throttle pedal and check to see if the LED on the module is lit. If the LED fails to illuminate, check the dip-switch settings, the VSS wire color and the connection to that wire. Check that the wire is on the right terminal at the module, and make sure there is a good power source and ground for the module.

While cruising at a constant speed, let off the throttle and let the vehicle slow below the set speed. The lock-up should release and the EBP Valve should disengage below the set speed. If these situations fail to occur, check the wiring to the EBP Valve and module, and also check the terminal locations on the module.

While at cruising speed and with the torque converter locked up, engage the cruise control. Then, while driving in lockup and with cruise control engaged, turn on the BrakeLoc, the cruise control should release and the BrakeLoc should engage. If the cruise control does not apply or release check the connections to the brake applied switch for continuity and all connections for security.

If any of the functions still fail to occur, phone our technical service department for further assistance. If it is required to bypass the effects of the module, unplug the Blue and Yellow wires at the transmission wire and plug the transmission wires together.

Ford Exhaust Brake RetroFit Kit (California Trucks)

BD Part number 1057020

The purpose of this kit is to cure the problematic Ford P-Code in regards to exhaust back pressure being too high. This code is normally set with California Powerstrokes when using an exhaust brake. This kit should only be used on California trucks that exhibit the problem.

To install, locate the Exhaust Back Pressure sensor at the front of the engine, just behind the idler pulley and to the left of the water pump outlet hose.

Install the supplied Posi-Tap™ connector on to the Violet with Light Blue wire (2000 – 03) or the Pink with Light Blue wire (1999).

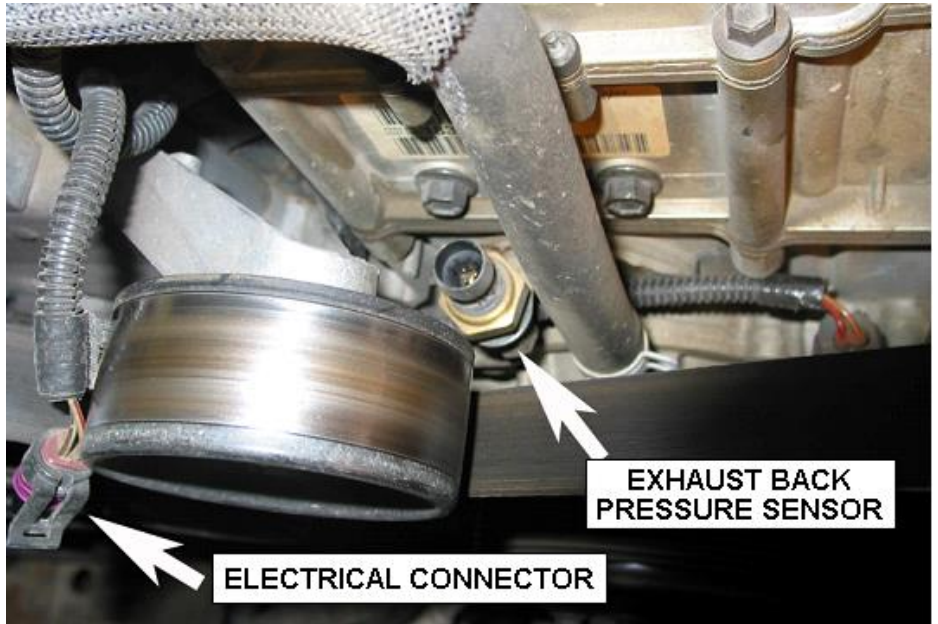

Connect the end of the black wire with ring terminal to a nearby engine fastener to provide a ground.

Do not cut or shorten the supplied wire. There is a diode located inside of it.

