



**DOWNLOAD THE LATEST  
INSTALL MANUALS AT  
[www.bddiesel.com](http://www.bddiesel.com)**







# **BD Adjustable Track Bar**

<b>1032111</b>	<b>Ford F250/F350 4WD 2017-2022</b>
	<b>Ford F450/F550 2017-2022*</b>

**Note:** 2017+ F450/F550 may require kit **1032110**. See **page 3** for details

**PLEASE READ ALL INSTRUCTIONS BEFORE INSTALLATION**

## Kit Contents

1303107	1303100-BC	1303103-BC	N807659-S441
			
Trackbar - Passenger Side (Left Hand Thread)	Trackbar Rod End (Right Hand Thread)	Threaded Connector	Track Bar Nut
<b>Qty: 1</b>	<b>Qty: 1</b>	<b>Qty: 1</b>	<b>Qty: 1</b>

1303102	1303105	1303104-01	1303104
			
Jam Nut 1 1/4 (Right Hand Thread)	Jam Nut 1 1/4 (Left Hand Thread- Arrow)	Bushing Sleeve	Polyurethane Bushing
<b>Qty: 1</b>	<b>Qty: 1</b>	<b>Qty: 1</b>	<b>Qty: 1</b>

## 2017-2022 F450/F550 Fitment

2017-2022 F450 and F550 vehicles may use track bars **1032110** or **1032111** depending on ball joint location. Please confirm the style of track bar used on your vehicle **before** ordering this kit.

**1032110** – Ball joint is pressed into the axle. Passenger side track bar has a tapered hole.

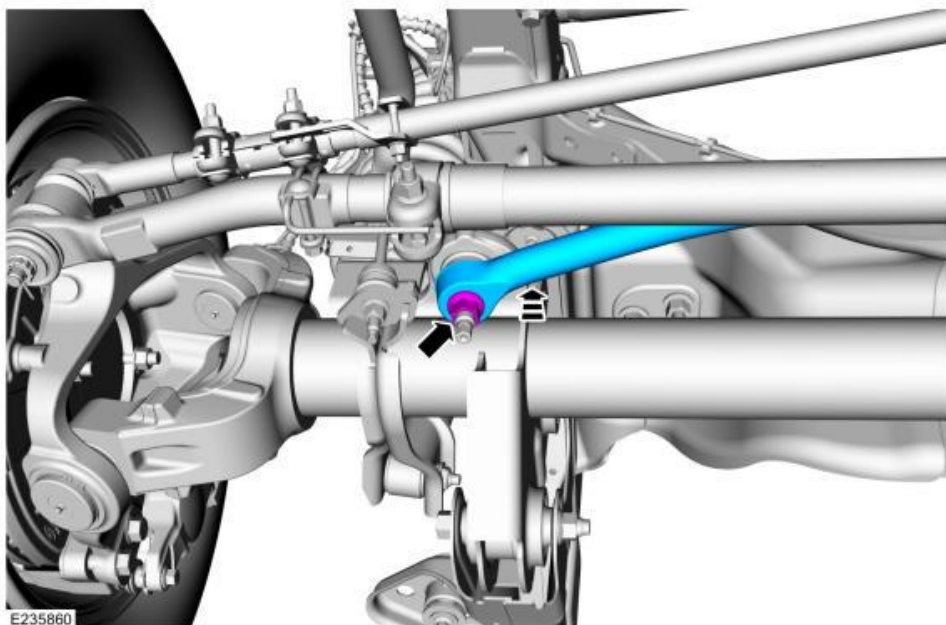

**1032111** – Ball joint is pressed into the passenger side track bar.

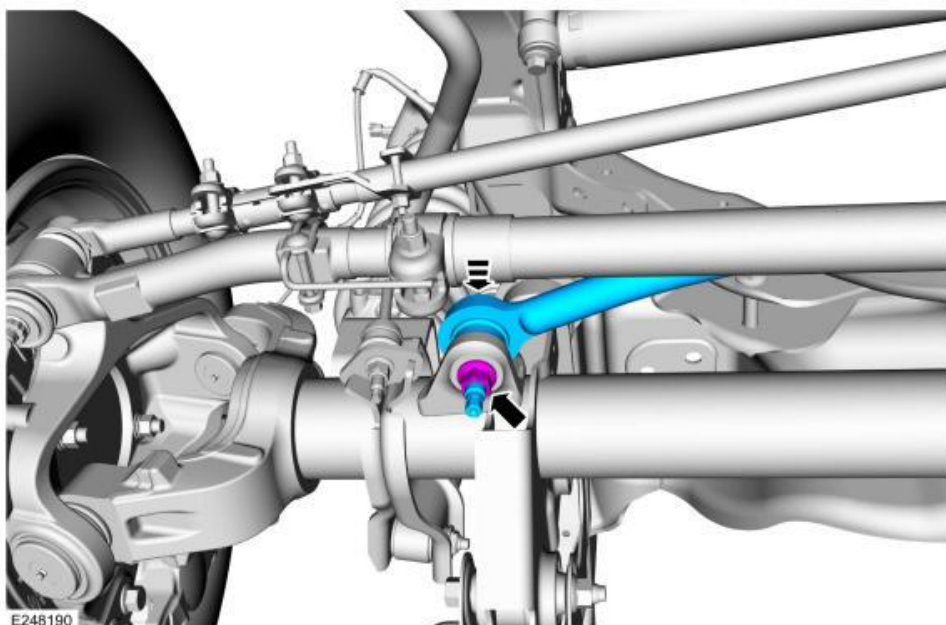

## ***Introduction***

Thank you for purchasing a BD Adjustable Ford track bar. This manual is divided into removal and installation sections to assist you with your adjustable track bar kit.

This product is a replacement for the factory track bar. If the securing mounts, have any signs of wear they should be fixed before installing the track bar. You will be reusing the factory hardware, if these bolts/nuts or ball joints show any signs of wear, replace them.

Installation should occur on a vehicle properly secured to prevent rolling.

## ***Tools Required for Installation***

- Arbor Press
- Torque Wrench (up to 406 lb-ft)
- Jack Stands
- 24 & 30mm Socket
- Impact wrench
- 13mm wrench
- 18mm Socket / Wrench
- File / flap wheel
- ½ Drive Torque wrench
- 3/8 Drive Torque wrench

## ***Installation***

### ***Removal***

With the vehicle in Neutral, lift vehicle by supporting the vehicles weight on the front axle to prevent the suspension from shifting when the track bar is removed.

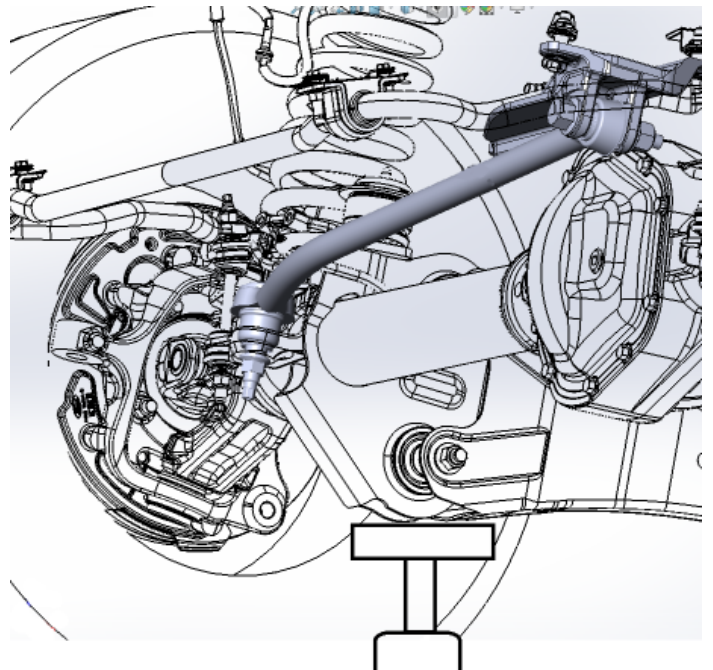



Position a jack stand under both sides of the front axle. Lower the vehicle until the front axle is supporting the vehicles weight.

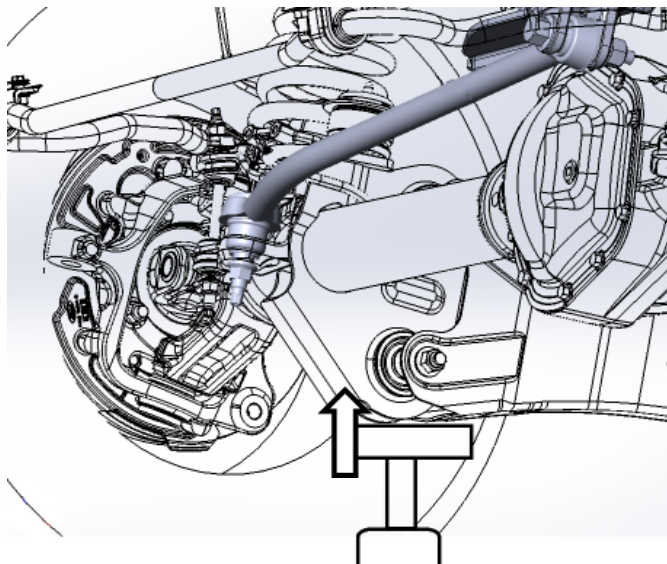

Remove the track bar-to-frame nut and bolt to disconnect the driver's side of the track bar (30mm socket).

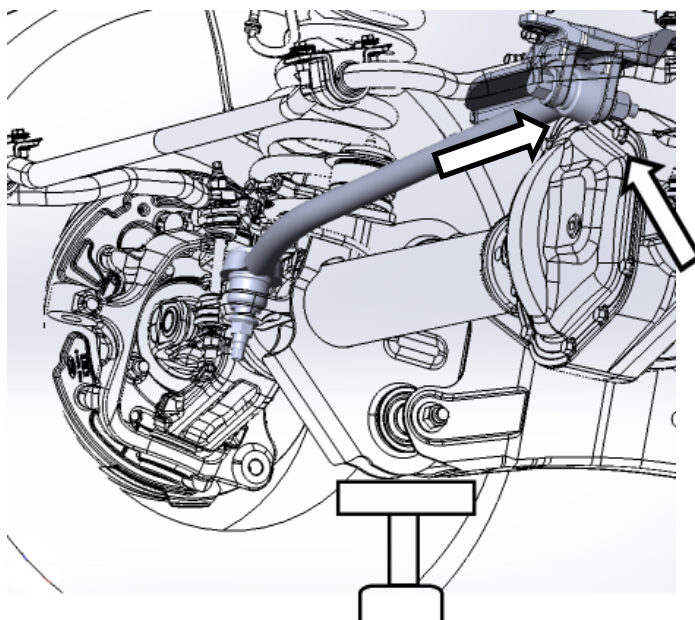

Remove nut from track bar ball joint. Disconnect the track bar from the passenger side and remove from the vehicle. (24mm socket)

**Note:** Use the hex-holding feature to prevent the track bar ball joint from turning while removing the nut.

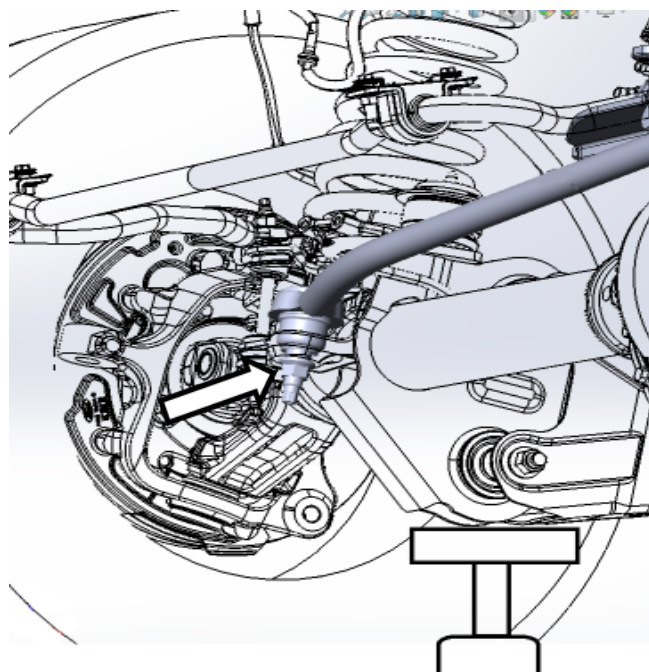

## Installation

Lubricate and press in the polyurethane bushing into the driver's side of the track-bar. Then lubricate & insert the steel bushing into the polyurethane bushing to complete the driver's side track-bar assembly.

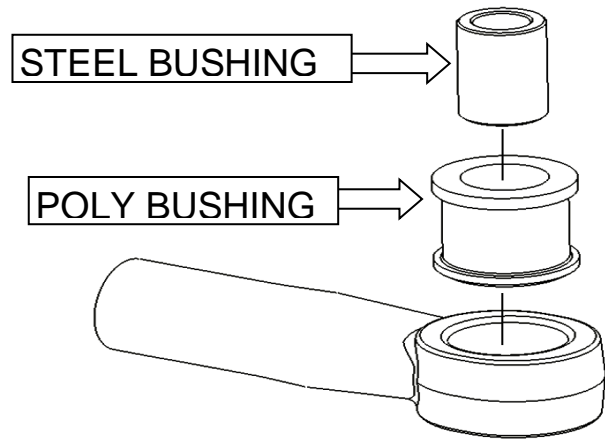

With bushing in place, connect all track bar pcs.

Thread nuts & ends all the way to the bottom. Then adjust from the center out so that the center-to-center distance of the connections is 36.75" (the same length as the stock bar) also ensure an equal amount of thread is showing on both sides of the connector.

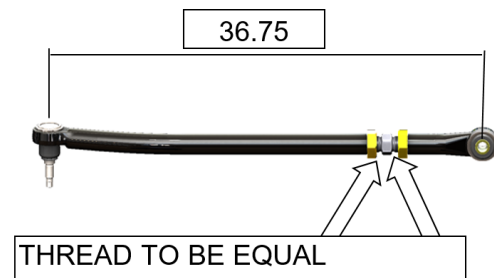

<b>SUGGESTED LENGTH</b>		
2017-2022	Length	Lift
<b>OEM</b>	<b>36.75"</b>	<b>0"</b>
<b>Leveled</b>	<b>37.18"</b>	<b>2.5"</b>
<b>Lifted</b>	<b>37.63"</b>	<b>4.5"</b>

Position the driver side of the track-bar into position and install bolt and nut snug. (30mm socket)

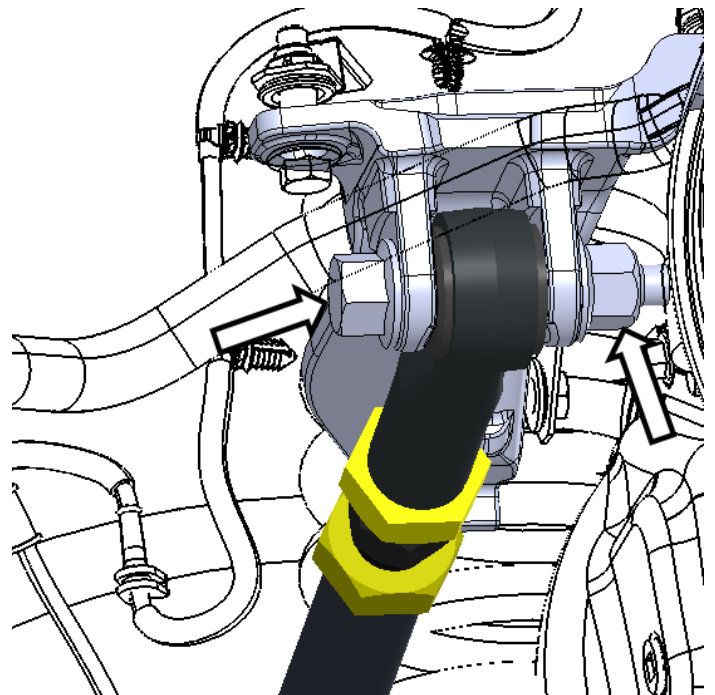

Position the passenger side of the track bar ball joint onto the frame and install supplied nut (N807659-S441) snug. (24mm socket)

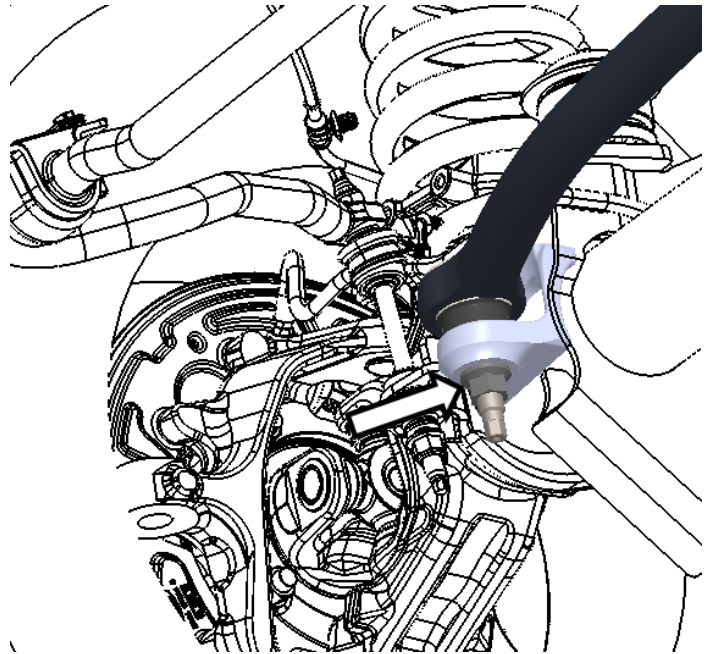

With the vehicle weight still supported by the jack stands, torque the passenger side ball joint connection to 184 lb-ft.

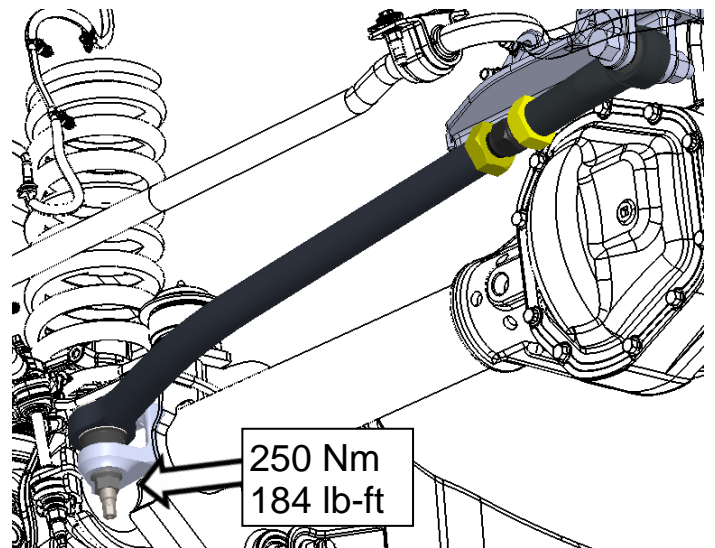

With the vehicle weight still supported by the jack stands, torque the D/S frame bolt connection to 406 lb-ft.

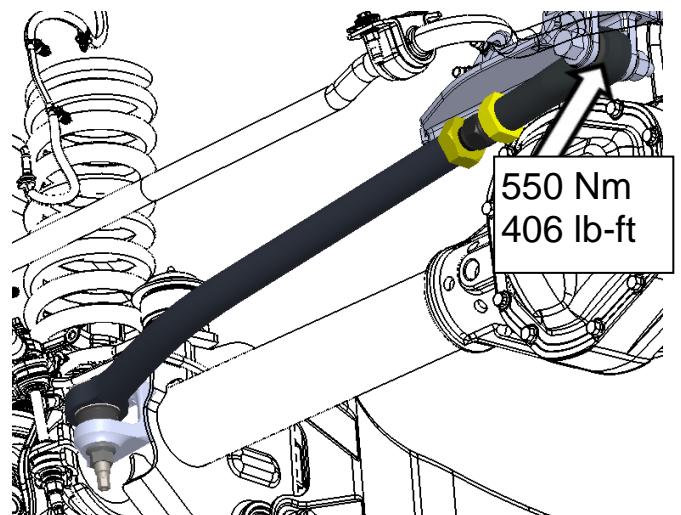

You can now perform an alignment on the front end of the vehicle. Adjust the front axle left and right by turning the threaded connector.

The shorter you make the track bar the more it will pull the front axle towards the driver's side, and vice versa.

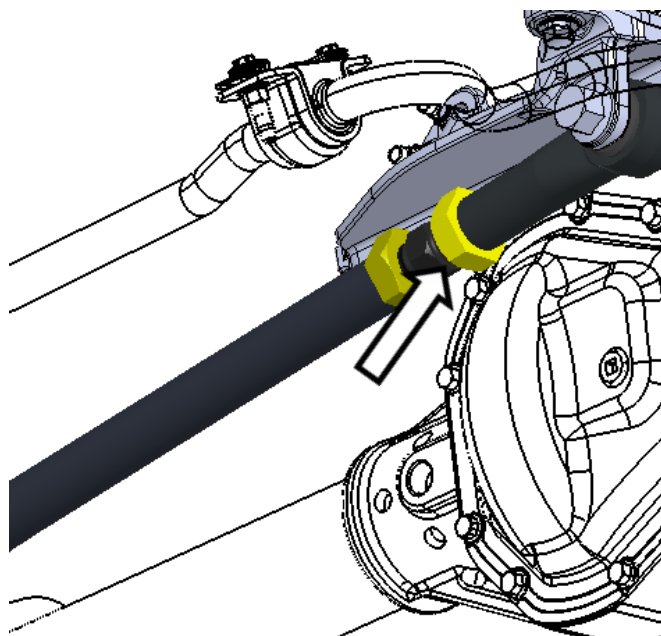

Once the alignment is complete, tighten the jam nuts to approximately 100 lb-ft of torque.

Do not drive the vehicle without torquing the jam nuts.

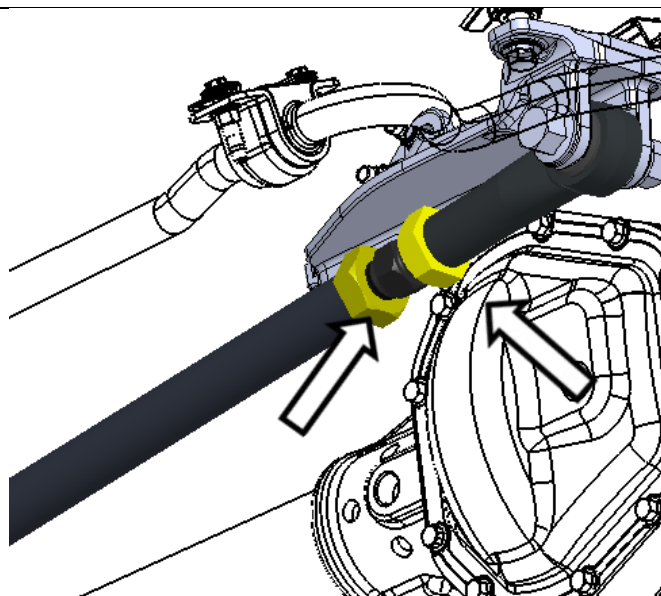

**DO NOT DRIVE THE VEHICLE WITHOUT COMPLETING A PROPER ALIGNMENT.**