



**DOWNLOAD THE LATEST
INSTALL MANUALS AT
www.bddiesel.com**







2013-2022 RAM Lift Pump Kit Installation Instructions



2013-2022 1050334



PLEASE READ ALL INSTRUCTIONS CAREFULLY BEFORE INSTALLATION



Kit Contents



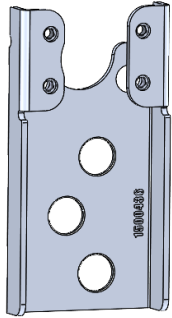

1500431-15	1500331
	
Venom Lift Pump; Assembled Qty: 1	Wiring Harness 2013+ Dodge Qty: 1

1505001	1604053	1330175
		
Hose Clamp Qty: 5	3/8" Fuel Hose Qty: 130"	5/8" ID Protective Loom Qty: 112"

1500311	1500428	1500419
		
-AN 8 ORB x 3/8" Barb Qty: 2	3/8" Quick Connect Straight Qty: 1	3/8" Quick Connect Female Qty: 1

FT-0141716	1500436	1500393	1500373
			
Bolt; M6x1 - 90mm SHCS Qty: 4	Bracket; Pump Qty: 1	Mount Strap 23.5" Qty: 2	Frame Bracket Qty: 1

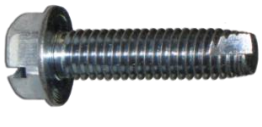
1500356	1300529	1300131
		
<i>Vibration Isolator</i> Qty: 3	<i>Self-Tapping Screw</i> Qty: 1	<i>Tie Wrap</i> Qty: 12

1900015	1402609	1500359	1500357
			
<i>Flange M8 x 30mm Bolt</i> Qty: 3	<i>M8 Flat Washer</i> Qty: 3	<i>Self-Threading 3/8" Bolt</i> Qty: 3	<i>3/8" Flat Washer</i> Qty: 3

1462115	1601522	1130058	FT-90700
			
<i>3/4" Insulated Clamp</i> Qty: 2	<i>M6 Flat Washer</i> Qty: 2	<i>Nylon Locking Nut M6x1</i> Qty: 2	<i>Flange Nut M6x1</i> Qty: 1

Introduction

The 2013+ RAM trucks with the 6.7L Cummins engine have a stock in-tank fuel pump capable of delivering enough fuel to support stock horsepower and mild engine modifications. For higher horsepower, more fuel supply is required and a high flow fuel pump is required.

The BD Diesel Venom fuel lift pump is a high-performance upgrade for your trucks fuel system that eliminates the factory fuel limitation. This lift pump can supply up to 165 gph of fuel, enough to support 900 horsepower.

Installing this kit is now easier thanks to the supplied quick connect fuel fittings which eliminate cutting the factory steel lines. This kit comes with 3/8" fuel line and fittings to connect to the factory system. See the next page for a list of optional accessories that can be used to get even more from your fuel system including 1/2" fuel line, draw straws, fuel bowl deletes, etc.



GEROTOR DESIGN

The Venom lift pumps are a high longevity gerotor design which results in low noise and high reliability.

Optional Accessories

1050331 Monster 1/2" Line Kit

Replaces the stock 3/8" line with 1/2" all the way from the tank to the engine. Includes fittings for the Venom pump and the CP3 as well as fuel hose and clamps. Requires use of sump or draw straw kit. Bypasses stock filters.



1050346 Fuel Heater Kit 12V 320W

Self-regulating 320W heater designed to prevent cold weather gelling of your fuel system with PTC heating element. Sandwiched between the water separator, pre-filter and/or the filter head.



1050330 High Flow Sump Kit

This kit installs in the bottom of the fuel tank to reduce restriction on the supply line. Kit can be installed without dropping the tank. Includes a screen to keep debris from entering the fuel line.



1050351 Flow-Max Water in Fuel Sensor

Relocates the stock WIF sensor from the fuel bowl on the engine to the Flow-Max water separator. Includes extension harness with built in resistor and new sensor that threads into bottom of the new filter. Requires 1050340-WSP. Use with fuel bowl deletes.



Tools Required for Installation

Required Tools

- Knife to cut fuel hose
- 5/16", 7/16", 9/16" and 10mm sockets
- Ratchet wrench
- 3/8" fuel line disconnect tool

Optional Tools

- Tape Measure
- Drill and 1/8" and 21/64" Bits
- Pliers
- 90 degree pick tool

Installation

Disconnect both vehicle batteries for safety.

Raise the vehicle on a hoist, or support the vehicle with jack stands for safety.

Fuel Tank Modification

Note: It is recommended to wait to begin installation when the fuel tank is almost empty or to siphon the tank down to reduce the weight to make it easier to remove.

Note: Removing the rear driveshaft makes fuel tank removal and future installation steps easier but is not explicitly required.

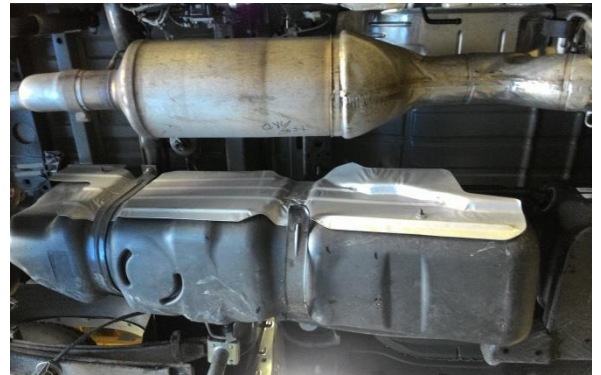

Loosen the fuel filler neck clamp and the clamp on the vent tube. Slide the rubber hoses off the rigid filler neck.

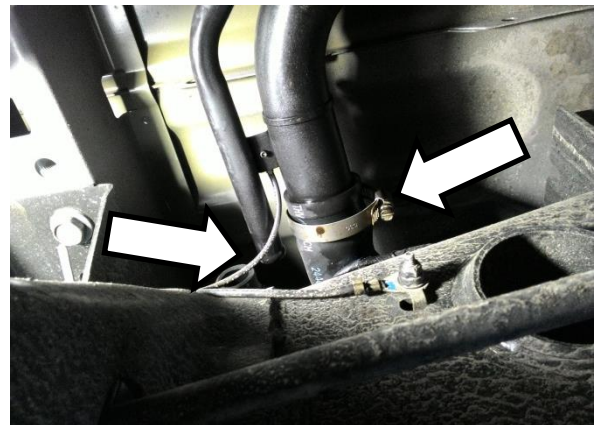

Support the fuel tank with a transmission jack or similar tool and remove the two fuel tank strap nuts.



Locate the small fuel tank vent tube which runs directly above the large filler neck. Follow this up the filler neck to the small breather. Cut the wire ties supporting this tube so that it can be removed along with the fuel tank.



Unclip the DEF tank hose support and release the hoses from the fuel tank.



Slightly lower the tank just enough to get your hand on top to disconnect the fuel lines and electrical connector.

Note: Do not let the tank hang by the fuel hoses!



Unplug the fuel pump module gray electrical connector.

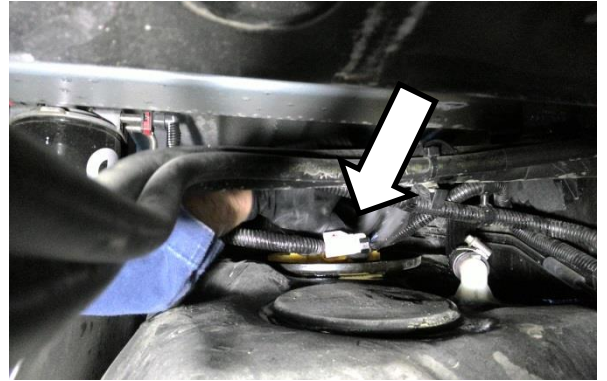

Disconnect the two fuel line quick connect fittings from the top of the fuel pump module.



Slowly lower the tank being careful to ensure the tank is not hooked on any wiring or hoses. Transfer the tank from the jack to a suitable work surface.

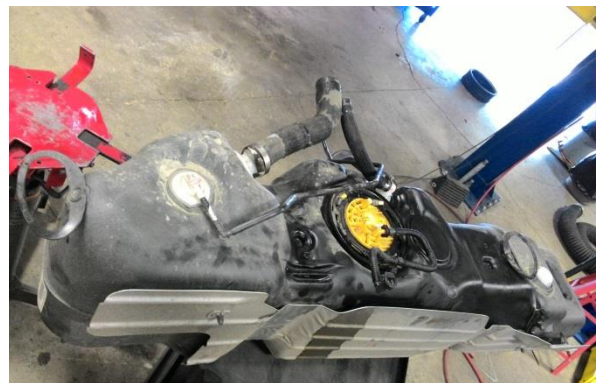

Before opening the tank up, thoroughly clean the area around the fuel pump module. Blow off with air and scrape off any dirt, debris and rust otherwise this will enter the fuel inside the tank.



Remove the lock ring from the fuel pump module by tapping it on the tangs with a mallet and screwdriver or suitable tools. Work around the ring to move it evenly to make removal easier.



Lift the fuel pump module out of the fuel tank being careful not to damage the fuel float arm or sender unit. Pour excess fuel from the bowl back into the tank.



Cut the larger of the two Teflon fuel pickup tubes at the top of the fuel module. Use a utility knife to create a slit in the tube. Cut the other end of the flexible tube off at the "H" adapter. Leave the other smaller tube in place and leave the return line in place.

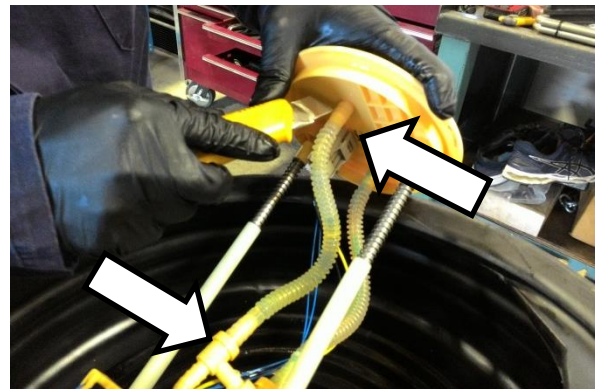

Cut off a short section of supplied black rubber hose (~approximately 16 in). Use one of the supplied hose clamps to attach the hose to the top of the fuel module assembly.

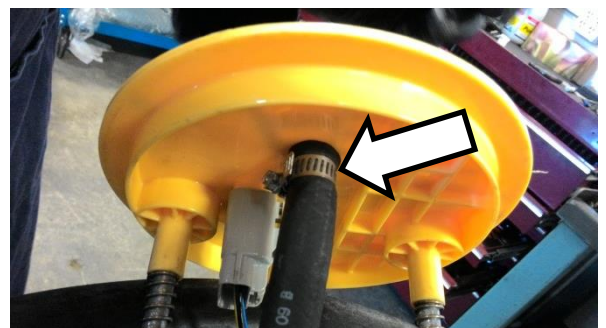

Check the length of the rubber hose by putting it in the fuel basket and compressing the fuel module assembly to the approximate installed height. The end of the rubber hose should be just off the bottom of the basket. Now cut a V notch in the bottom to ensure that if it contacts the bottom of the fuel basket it won't stop the flow of fuel.



Use a wire tie to hold the fuel hose in the basket by gently tying it to the original fuel pump plastic bracket. Do not make this tie too tight or it will pinch the fuel line.

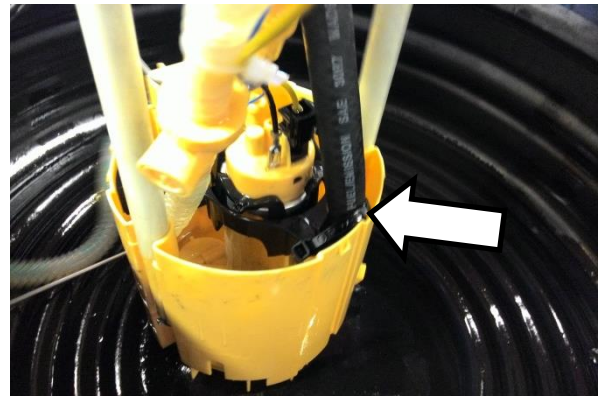

The fuel pump module assembly is now configured with the feed line drawing directly from the fuel basket, bypassing the factory fuel pump. The return line portion should be left stock.



Ensure the fuel tank gasket is clean. Reinstall the basket in the tank and reinstall the lock ring in the reverse manner of removal. Note the fuel pump module will only fit in the tank one direction due to a locator tab.

Do not install fuel tank until wire harness is installed.

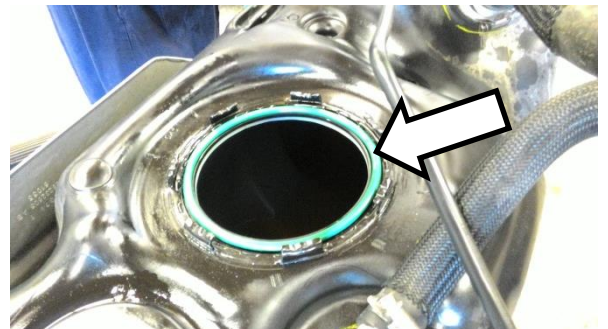

Venom Wiring Harness Installation

Locate the harness supplied in the kit. Mount the relay socket in the engine bay near the top of the firewall at the driver's side. Zip tie it to the existing engine bay wiring there. Alternatively, you may use a self-tapping screw to secure the relay socket.



Unclip the windshield washer hose support from the ground stud on the driver's side of the engine bay.

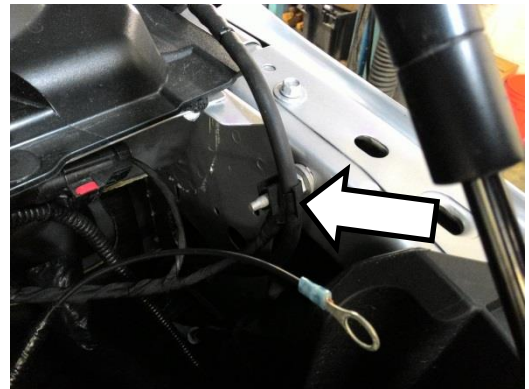

Install the black ground wire from the BD harness onto the ground terminal stud. Use the supplied M6 nut to fasten the terminal. Reinstall the windshield washer fluid hose support.

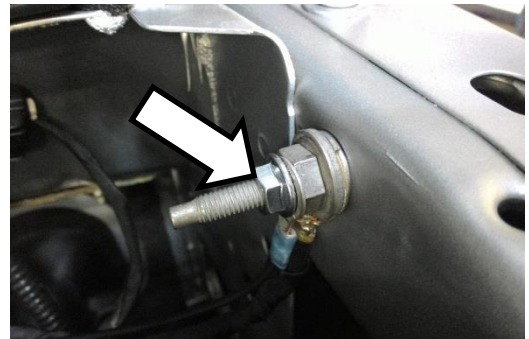

Open the fuse box lid and remove the large nut securing the fuse box power feed. Install the battery power wire (red or orange) from the BD harness on the stud and reinstall the nut.



Feed the two remaining portions of the BD wiring harness down the firewall to the driver's side frame rail. These will be run to the fuel tank and the new Venom fuel pump.



The two-pin gray plug will connect to the Venom fuel pump in a later step. Leave this wire for now.

NOTE: Picture illustrates Venom pump which is not yet installed.



Route the longest section of harness along the frame rail all the way back to the fuel tank. The 4 pin gray plug will connect in line with the original fuel pump connector. This will serve as a trigger for the new fuel pump relay. This is easiest to install before the fuel tank is reinstalled. Secure the wiring with tie wraps.



Now that the fuel pump module electrical connector has been installed, the tank may be installed, or optionally left out until the end of the installation. Installation is the reverse of removal.

Venom Pump Mounting

Position the frame mount bracket on the **outside** driver side of the frame and determine mounting location. The suggested location is below the rear driver's door over top of the Parking Brake cable.

The bracket provides clearance so that the cable will not touch.

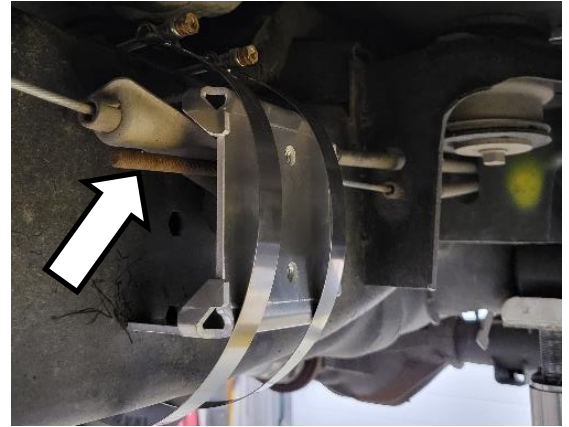

On the inboard side of the frame, pop out the wiring harness clip. This will allow for installation of the band straps.

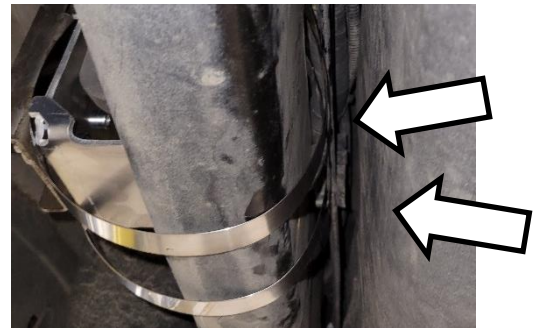

Slide the two band straps under the brake lines around the frame and ensure no wiring or other lines will get pinched by the straps.

Orient the straps so that the threaded stud end is on the top to make tightening easier.

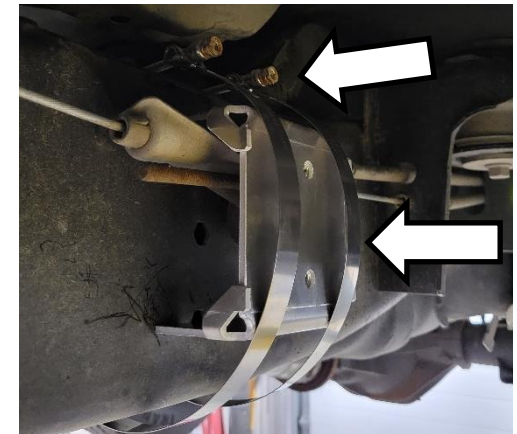

Position the fuel pump bracket under the band straps. Start the nuts by hand and tighten the band straps until the bracket is snug. There is no need to overtighten these straps, the nuts are self-locking and will not back off.

Recommended torque: **80 in-lbs.**
Ensure straps rest nicely on the bracket.

Note: Center hole is to be positioned to the left.



Insert the three vibration isolators in through the back side of the Pump bracket and mount to the frame bracket using the M8 bolts and washers.

Tighten to **12 lb-ft.**



Mount the Pump to the frame using the four M6 bolts. Torque the four bolts to **8 ft-lbs.**

Screw in the 3/8" barb fitting on either end of the pump.

Due to mounting on the outside of the frame, the pump will be installed to the bracket with the diaphragm cap facing outwards as pictured.

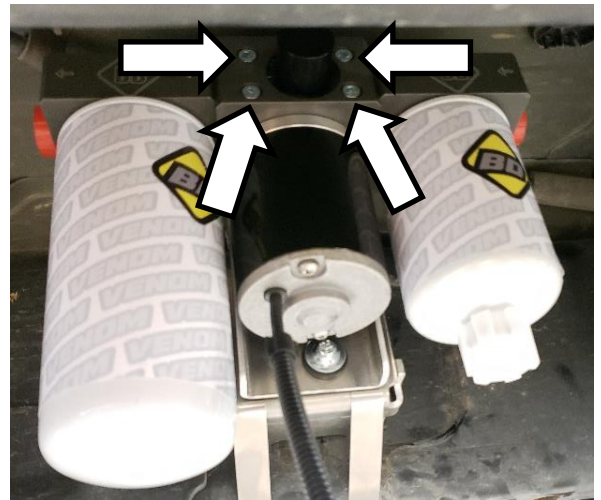

Fuel Line Routing

Locate the stock fuel line disconnect at the fuel pump module. Disconnect the supply line to the fuel filter housing.



Install a 3/8" quick connect straight fitting into the supplied 3/8" fuel hose.



Feed the fuel hose over the frame rail from the Venom pump to the OE fuel pump module that was just disconnected to determine the required length and cut the hose to length. (Approximately 62 inches).

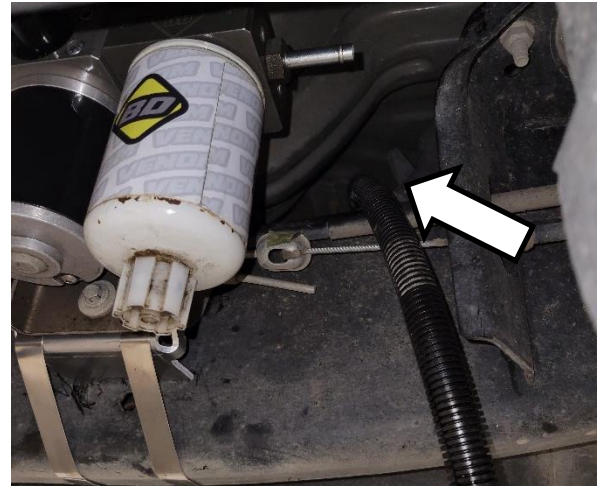

Install a section of the supplied protective loom over the hose. This will help protect it from abrasion.



Install the hose assembly onto the pump module and route it over the tank.



Connect the other end of the hose to the Venom pump using a hose clamp.

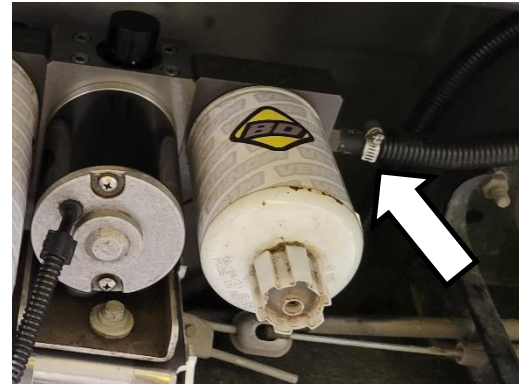

Locate the factory fuel line disconnect at the stock rear fuel filter, located beside the fuel tank. We want to disconnect the inlet from the filter as this is where the Venom pump will deliver fuel to. This is the fitting towards the back of the truck.



Pull out the red locking tab using a pick or similar tool. Push in the release button on the top side of the quick connect fitting to disconnect it from the filter housing.

Fuel may drip out when disconnected, position a drain pan below.

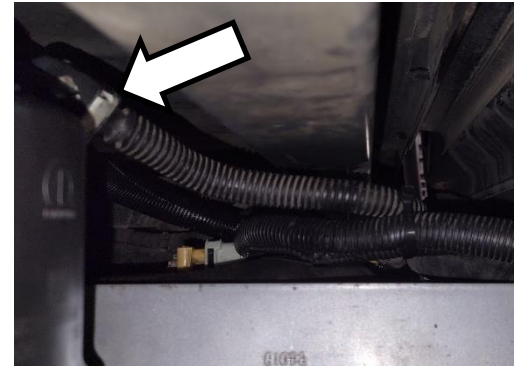

Install the quick connect fitting into the end of the remaining fuel hose and install a clamp.



Install the remaining split loom over the hose for protection.

The hose and loom will be trimmed to length during the following installation steps.



Connect the quick connect fitting to the inlet of the fuel filter assembly. Fish the other end of the hose over the top of the fuel tank, so that the hose crosses the frame rail as shown in the pictures below.



Now that the hose is routed correctly, trim it to length to reach the Venom pump (approx. 68 inches).

Trim back the split loom a couple of inches to allow clamp installation. Install the hose clamp.



Finally, plug in the Venom pump to the wiring harness that was installed earlier.

Ensure to use zip ties to hold the harness secured to the frame.



All of the fuel line routing should be complete. Check the lines are adequately supported. Ensure no fuel hose is exposed to possible chafing as that can rub through the hose.

Installation should now be complete. Reconnect batteries, and test the pump for operation. Upon key on, you should hear the pump running.

If the pump motor does not run or there is a pressure or supply issue, refer to the end of the manual for troubleshooting.

Mounting Option 2 - Mounting the Pump Bracket to the Frame

Place fuel pump and bracket in place to ensure ample clearance. Then, use the fuel pump bracket as a template and mark the locations to be drilled.

Mark holes with center punch. Drill pilot holes to 1/8". Drill main holes to 21/64". Insert the three rubber isolators into the support bracket.

Place the large washers on the inside of the bracket against the rubber isolator.

Using an air ratchet (9/16" socket) tighten the self-threading 3/8" bolt through each hole in the support bracket assembly and into the frame. Repeat this step for the other 2 bolts.

Torque the three bolts to **25 ft-lbs.**

Flow Specifications

- Flowrate should be MINIMUM 2.75 GPM (165 GPH) @ 14VDC
OR
- Filling a 1-gallon container every 22 seconds @ 14VDC
- Expected Idle pressure 15-18 psi
- Minimum 8 psi @ Wide Open Throttle

Fuel Line Routing

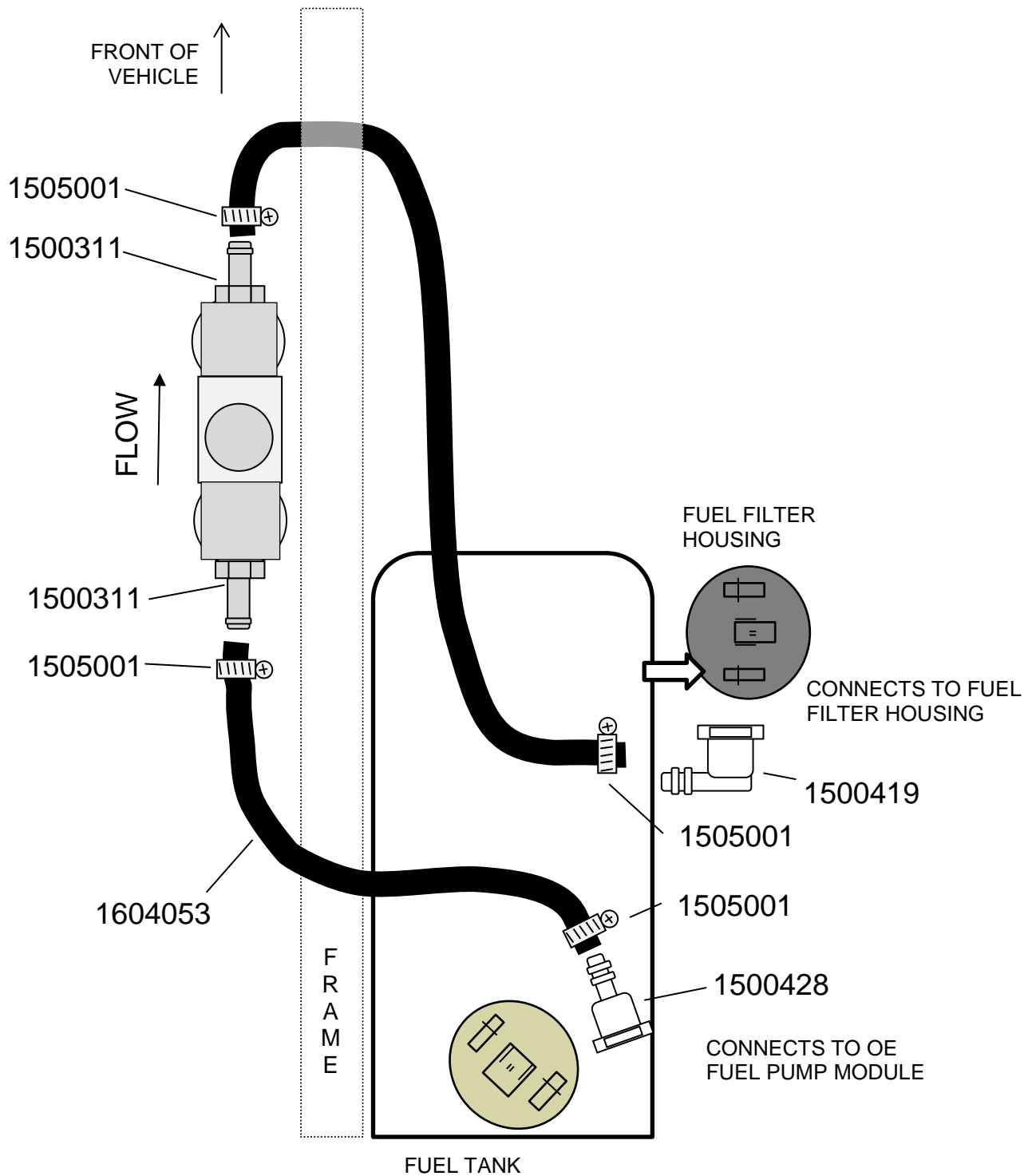

Wiring Harness

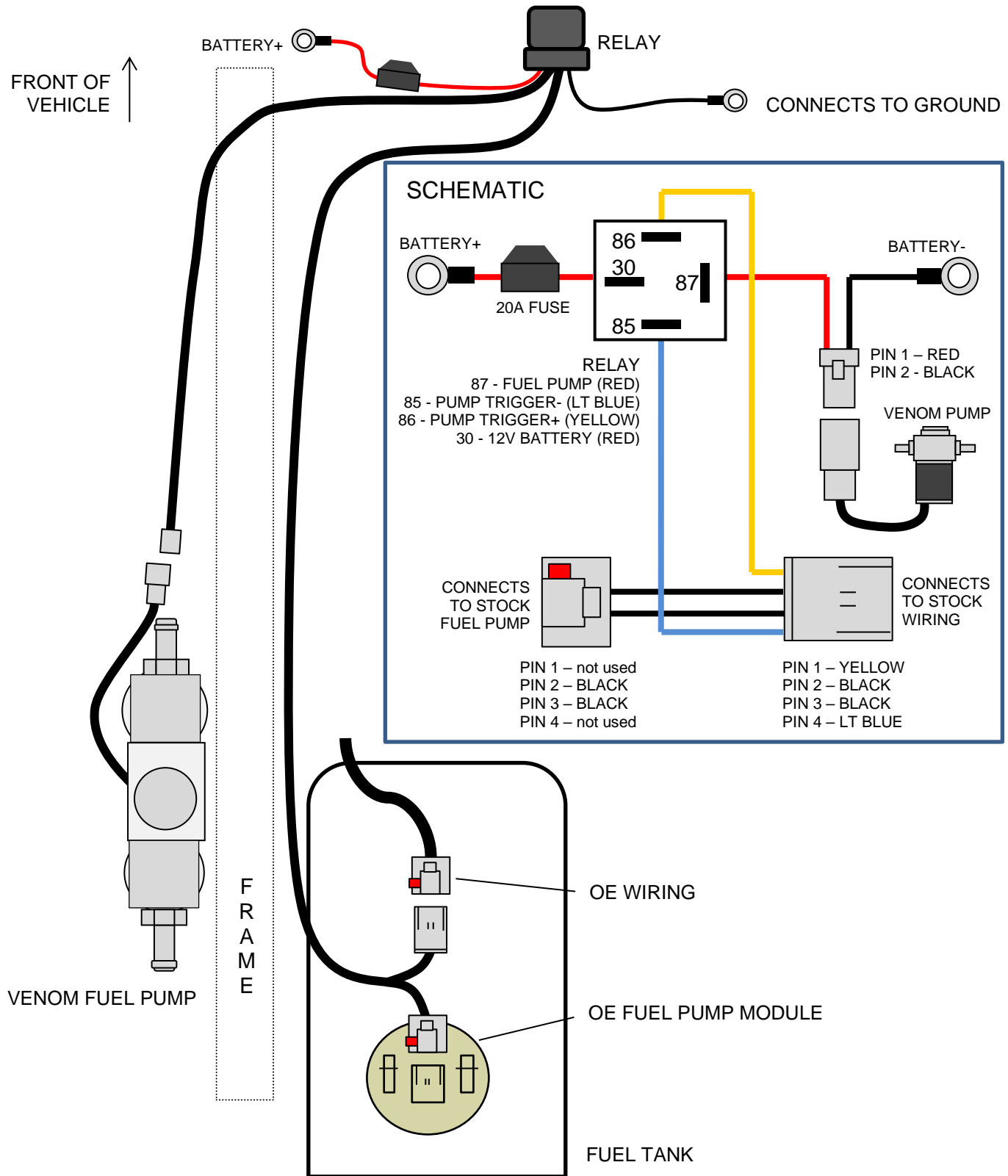

Trouble Shooting

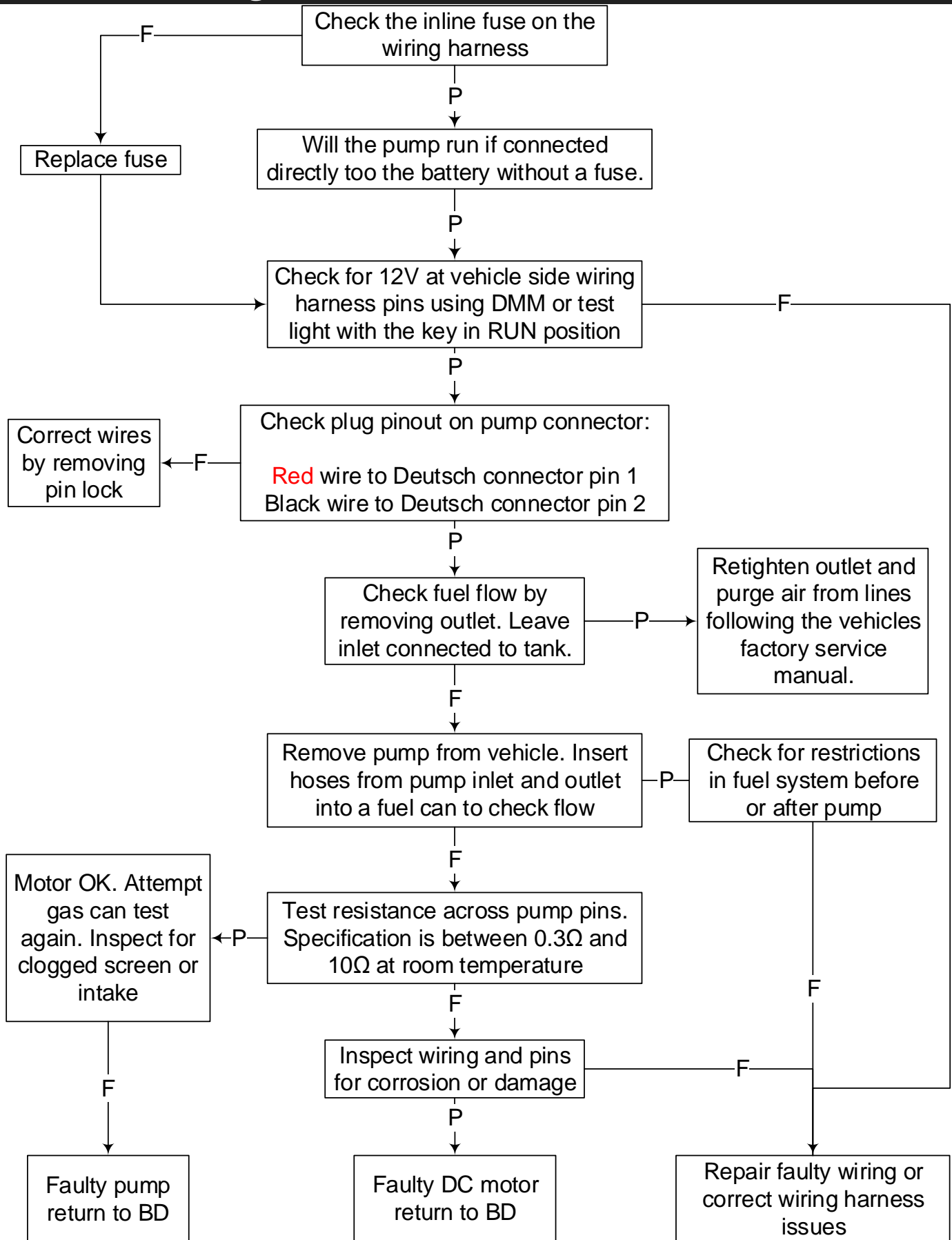

Update a Flowmax Pump to a Venom Pump



Replacement Center Section

If the center section needs to be replaced, a **1500430-15** may be ordered as a replacement. Contact BD Diesel for more details.



Replacement Filter Cross Reference

The Venom Lift Pump kit is supplied with a water separator and fuel filter combo. The replacement filter parts through BD are listed below with equivalents.

Water Separator		Fuel Filter	
BD Diesel	P550550-VEN	BD Diesel	P551315-VEN
Donaldson	P550550	Donaldson	P551315
Baldwin	BF1275	Baldwin	BF7634
WIX	33616	WIX	33626
Luber-Finer	LFF9594	Luber-Finer	LFF4783